

Case Unit SMA_UU

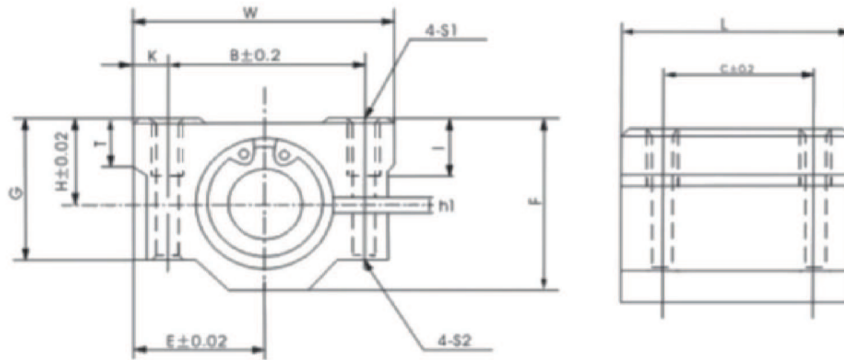

MODEL	SHAFT DIAMETER	MAIN DIMENSIONS							MOUNTING DIMENSIONS						WEIGHT [Kg]
		H	E	W	L	F	G	T	B	C	K	S1	S2	I	
SMA8UU	8	11	17	34	30	22	18	6	24	18	5	M4	3.4	8	0.052
SMA10UU	10	13	20	40	35	26	21	8	28	21	6	M5	4.3	12	0.092
SMA12UU	12	15	21	42	36	28	24	8	30.5	26	5.75	M5	4.3	12	0.102
SMA13UU	13	15	22	44	39	30	24.5	8	33	26	5.5	M5	4.3	12	0.12
SMA16UU	16	19	25	50	44	38.5	32.5	9	36	34	7	M5	4.3	12	0.2
SMA20UU	20	21	27	54	50	41	35	11	40	40	7	M6	5.2	12	0.255
SMA25UU	25	26	38	76	67	51.5	42	12	54	50	11	M8	7	18	0.6
SMA30UU	30	30	39	78	72	59.5	49	15	58	58	10	M8	7	18	0.735
SMA35UU	35	34	45	90	80	68	54	18	70	60	10	M8	7	18	1.1
SMA40UU	40	40	51	102	90	78	62	20	80	60	11	M10	8.7	25	1.59
SMA50UU	50	52	61	122	110	102	80	25	100	80	11	M10	8.7	25	3.34
SMA60UU	60	58	66	132	122	114	94	30	108	90	12	M12	10.7	25	4.72